



MODEL TT2 TRASH DUMP TRAILER

18 ft 20 cu yd
18 ft 25 cu yd



Our Standard Trailer is Heavy Duty!

- Available with single or dual axle
- Electric Brakes are standard
- No 90 degree angles on body sides helps prevent rust
- Body lights inset or flush mounted
- Single sheet 3/16" floor
- 10 gauge sides, headboard, and doors
- Side stakes 3" x 4" formed channel
- 4" cross sills on 12" centers



Comes standard with latching barn doors & six 3/4" fabricated plate hinges



Designed for use with a Petersen model RL-3 Lightning Loader grapple truck



Trailer includes 3" pintle eye, jack stand, quick couplers, and 15,000 lb. capacity draw bar

**THE INDUSTRY STANDARD SINCE 1979
EFFICIENT! VERSATILE! AFFORDABLE!**



Specifications & Technical Data*

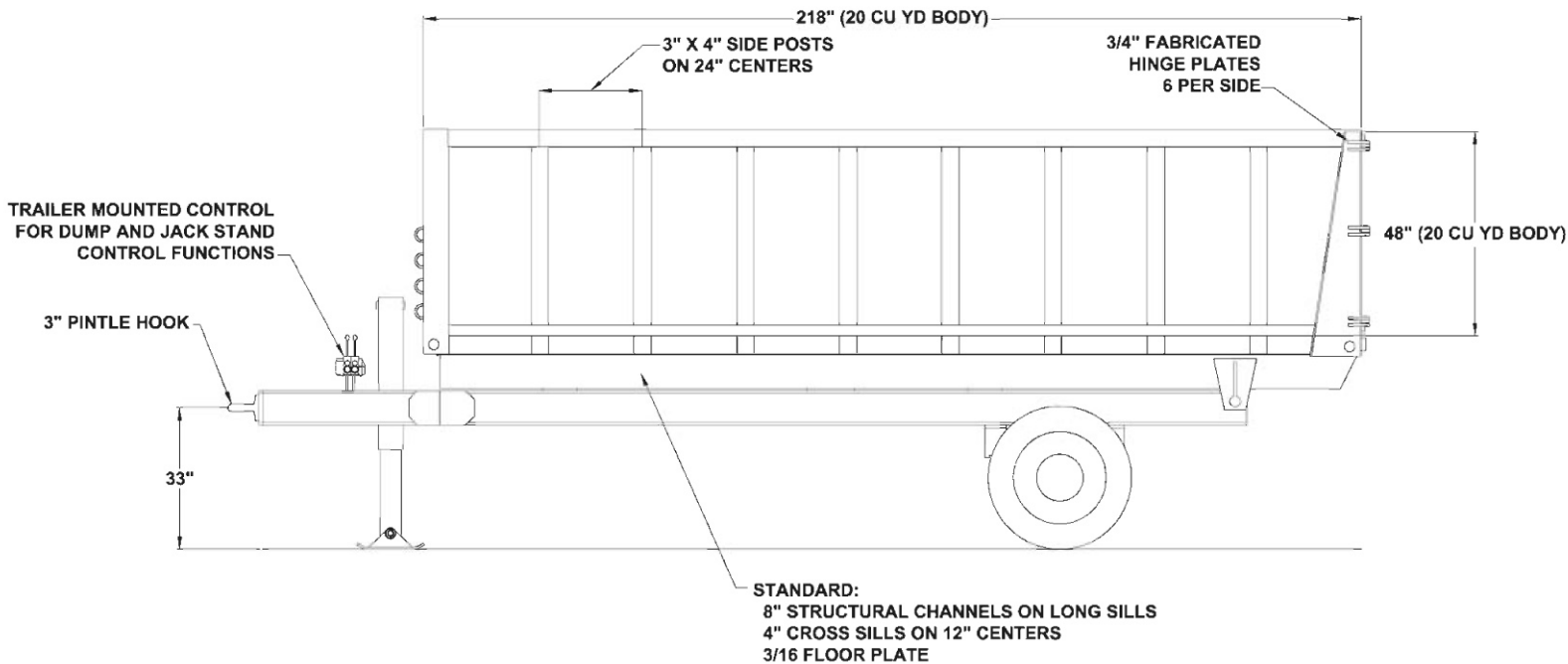

- BODY FLOOR** 3/16" single sheet steel plate
CROSS SILLS 4" structural channel on 12" centers.
HEADBOARD 10 gauge steel continuously welded to the floor. Top rail is 3" x 4" formed channel.
BODY SIDES 10 gauge steel continuously welded to the floor.
SIDE POSTS 3" x 4" x 10 gauge formed channel on 24" centers. 1/4" steel plate formed rear corner posts.
BARN DOORS Top and bottom positive locks. Three hinges per door with two 5/8" thick straps.
BODY HOIST 12 ton dual hydraulic cylinder hoist.
FRAME 2" x 8" x 1/4" steel tubing with 6 cross members. Long members are one welded piece from pintle eye to hinge.
SINGLE AXLE 15,000 lb. capacity with dual wheels and tires. Electric brakes are standard. (also available with tandem axle)
DRAW BAR Vertical load capacity of 15,000 lbs. and 3" pintle eye.
BODY LIGHTS Meets federal lighting standards. Mud flaps installed behind rear wheels.
PAINT High grade primer and enamel finish.

All Petersen trailers include manual jack stand mounted on tongue of trailer with sufficient capacity for disconnecting loaded trailer. One control valve is included for operation of hoist. Additional control valve will be included if optional hydraulic jack stand is used. Quick couplers on hydraulic lines and electrical hookup, including lights and brakes.

The Petersen "Lightning Loader" has been the industry standard for economical, quality trash loading equipment for more than 25 years. More than 3,500 units have been tried and tested in over 750 municipalities nationwide and abroad. The Petersen Lightning Loader® has an established track record and a reputation as the highest quality, most reliable loading equipment available.

Petersen manufactures nearly all major components for its Lightning Loader® systems. Truck mounted units are assembled, fully installed and tested at Petersen's plant in Lake Wales, Florida. With complete CNC lathes, machining and fabrication facilities, Petersen is able to control every aspect of production schedule and quality control. The Petersen team of experienced management, sales staff, and manufacturing technicians work hard to provide our customers with the best specialized equipment in the industry.

OPTIONS

- Electronic load covering device
- Manual load covering device
- Twin 10,000 lb. axles
- Air brakes
- Hydraulic jack stand
- Self dump power pack
- 3/16" reinforcement plates between floor and sides
- Continuous welds for side posts
- Six inch dual cylinder hoist (18 ton)
- LED lights

*We reserve the right to change product design and specifications at any time without notice. There may be more specifications than are listed here. Consult your Petersen dealer for complete specifications.



Petersen Industries, Inc.

Your Authorized Dealer is:

Municipal Equipment Sales, Inc.

Mailing Address: PO Box 1233
 Location: 208 Bell Place
 Woodstock, GA 30188

Local: 770-928-0424
 Fax: 770-928-7512
 Nationwide Toll Free: **1-800-782-2243**
 Email: sales@municipalequipment.com
 Web: www.municipalequipment.com

